

BULK PLANT GAUGES

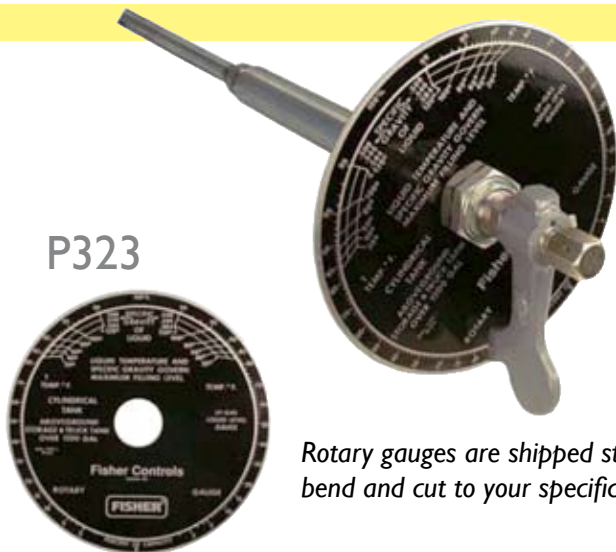

Rotary gauges are shipped straight - bend and cut to your specifications.

FISHER

J31L

Fisher rotary gauges can be used on stationary or mobile tanks to visually indicate the amount of LP-Gas or NH₃ in the container. They are also used in filling the tank to the proper liquid level. On mobile applications and some large stationary storage tanks, hangers are recommended to support the horizontal length of the dip tube.

The gauge is operated by opening the small bleed orifice when the tube is in the vapor space of the tank. Moving the pointer on the dial causes the end of the tube to move until it contacts liquid in the container. At that point, discharge from the bleed orifice turns from vapor to liquid and the rotary gauge dial gives the volume percentage of liquid in the tank.

Type J31 consists of heavy duty gauges that minimize vibration effects (swaying, bouncing) by a long (68") stem tube extension. Gauges fit 1" coupling container connections.

All gauges have stem and dip tubes with an extra large inside diameter. This assures that the correct liquid level can be obtained quickly.

A nylon packing sleeve and a friction ring for the pointer indicator gives smooth rotation and long service life. Steel and stainless steel materials resist rust or corrosion.

Rotary Gauges

Length in Inches (Diameter of Tank)	Model Number
68	J31L-1
69-92	J31L-2
93-108	J31L-3
109-140	J31L-3L
Dial only LP	P323
Dial only NH3	P324

Rotary Gauge Repair Parts

Description	Part Number
Cap & Seat, 11/16" HEX	T10971 - Current
Cap & Seat, 3/4" HEX	T11141 - Older
Packing Sleeve	T10956

BULK PLANT GAUGES-VISUAL



(For 108" Diameter Tank-End Mount)

The ME series Master tank gauges come complete with a 10" dial and 8 mounting bolts. The 2" mounting flange (ME931) is not included and should be ordered separately. The ME931 mounting flange is zinc plated for corrosion resistance. Gauges for different size tanks are available, specify inside diameter and mounting position.

Part Number	Description
ME2434B	Squibb 72" Float Gauge w/10" Visible Dial - LP Only
ME2839B	Squibb 84" Float Gauge w/10" Visible Dial - LP Only
ME3650B	Squibb 108" Float Gauge w/10" Visible Dial - LP Only
ME3862B	Squibb 130" Float Gauge w/10" Visible Dial - LP Only
I30035	10" Squibb Master Dial LP Only (use w/ 5331)
I30040	Flexitallic Gauge Gasket 2 1/4" ID x 2 11/16" OD
I30219	Master Gauge Bolts - 8 required
I30204	Master Model B Float Bulb for Master Gauges,
ME931	2 1/2" x 8 Bolt Flange Tank Mount for 8" or 10" Dial
15-19	Metal gasket for Magnetel or Rough Rider Gauges
15-10	8" Rubber Gasket for Dial Glass (2 Required)
3-22	8" Dial Tempered Glass Crystal
5015S01403	8" Rochester Dial Assy, LP or NH3
93-403	8" Rochester Dial Mounting Bracket
56-00404	Rochester Magnetel 1/2" Mounting Stud Bolt

MAGNETEL ROUGH RIDER VISUAL TRUCK GAUGE

Rochester

Rotary Gauges

Part number	Description
CM 6339-11-X	4" Gauge Complete, x = Tank diameter
5331	2 1/2" NPT Mounting Flange
5137S01262	4" Dial Assembly
3-408	4" Dial
15-451	4" Dial Gasket
40-413	Screws for 4" Dial



CM6339-11-X

5331



ROADMASTER VISUAL TRUCK GAUGE

The Roadmaster - unique for mobile applications.

Uniquely designed to withstand the tough-shock and vibration associated with mobile-service of LP-Gas and Anhydrous Ammonia.

Specifically designed to operate within the standard working pressures of LP-Gas and NH₃ applications. Incorporates a special spring designed to substantially reduce stress on conventional float-type gauges on mobile applications. Standard and easily replaceable 4" easy viewing dial. Applicable to end or side mounting. Ideal for new or replacement installations.



RM1833

SQUIBB TAYLOR

Roadmaster Visual Truck Gauge

Part Number	Tank Diameter
RM1833	72"
RM1836	79"
RM2440	82"

Bergquist

FLOAT GAUGES FOR BULK TANKS AND LIFT TRUCK CYLINDERS

* Junior and Senior gauges are complete with gasket and four screws

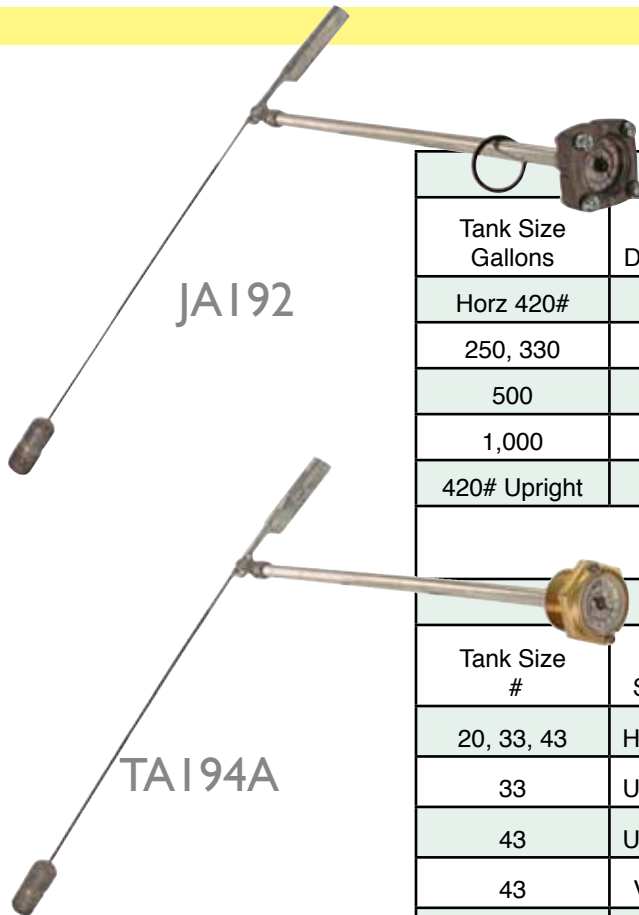

Float Gauges for Bulk Tanks					
Tank Size Gallons	Tank Diameter	Junior Head*	Senior Head*	Screw In 1"	Screw In 1 1/4"
Horz 420#	24	JA124I	--	--	TA130A
250, 330	30	2070.U	SA160A	2070.U1	2070.U1-1/4
500	37	2071.U	SA194	2071.U1	2071.U1-1/4
1,000	41	2072.U	SA214A	2072.U1	2072.U1-1/4
420# Upright	30	6281-85	SA230E	G12427	7281-85

Float Gauges for Lift Truck Cylinders					
Tank Size #	Type Service	Junior Head	3/4 NPT	1 1/4 NPT	
20, 33, 43	Horizontal	JD060A	--	7284-24	
33	Universal	JU160B	UU160B	TU160B	
43	Universal	JU212A	--	TU212A	
43	Vertical	--	--	TA216A	
20	Universal	6284-33	7384-1005	--	

SPECIAL ORDER GAUGES

In addition to the standard gauges, special order gauges are available. Delivery time is approximately 2 weeks on special order gauges.

We will need to know;

- Gauge Head Type... (A) Junior 4 Bolt (about 2" diagonal - bolt to bolt)
(B) Senior 4 Bolt (about 2 1/2" diagonal bolt to bolt)
(C) Threaded Screw-In (3/4", 1", 1 1/4" NPT)
- Tank Diameter _____ inches in diameter
- Gauge Location Top, at 45°, or at 90°
- Rise Off Tank is there a rise off the tank surface - as on an underground domed tank.

We also have a limited number of expandable gauges which can be made and shipped the same day. Check with an inside sales representative for availability.

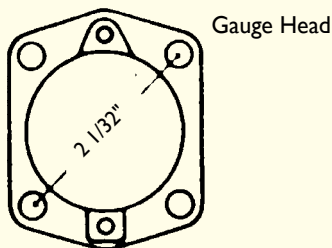

Junior Gauge
2 1/32" Bolt Circle

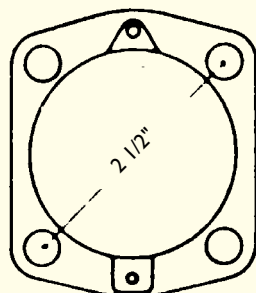

Senior Gauge
2 1/2" Bolt Circle

