

Hannay Reels and Reel Parts

17.0060

Junction Boxes



Part No.	Description
17.0060	Round Junction Box
17.0030	Square Junction Box

Since 1933 Hannay Reels has set the standard for quality, service, and delivery. The modern state-of-the-art facility in Westerlo, New York produces over 70,000 reels a year, ranging in size from hand portables to reels over 12 feet in length. The propane delivery reels are now produced in standard painted steel, polished aluminum, or unpolished 304 sst.

Things to consider when ordering a new reel;

1) Capacity - how many feet of 1" hose do you want on the reel. Typical lengths are 100', 125', and 150' (125' is the most common).

2) Which side do you want the 1 1/2" inlet and 12 volt motor located on? (as you look at the reel).

3) Do you want an auxillary hand crank?

4) Do you want any roller assemblies?

5) Would you like the reel to be top wind or bottom wind?

6) Would you like a Guidemaster installed?

Notes: 1.) If you have the model and serial number of a reel you now have and like, Hannay can duplicate it.

2.) "Spool Assembly"...If you want the disc & drum width brackets to fit your old reel, order a spool assembly by model and serial number. Specify how complete you want the assembly - then just drop it in the old frame and piping.

CIRCUIT BREAKERS

17.0021



CB-2 (17.0024)



Circuit Breakers

Part No	Description
17.0021	50 Amp Breaker
17.0022	70 Amp Breaker
17.0024	CB-2 Bracket
17.0025	12 Volt Solenoid



17.0025

OPERATING SWITCHES FOR ELECTRIC REWIND REELS

EPS-1 (NEW STYLE)

Part No.	Description
17.0200	New EPS-1 Switch Complete
17.0207	Bracket New EPS-1 GM700
17.0205	Bracket (Old) EPS-3 GM600
17.0208	Top Side Universal Bracket
17.0004	Capped Push Button Switch
17.0008	Rubber Cap only



EXPB-2A

Part No.	Description
17.0001	Switch Complete - 12 Volt
17.0014	Internal Switch
17.0015	Red Dot Repair Kit



Swivel Joint Repair Kits

Part No.	Description
SMAC-112SK	Repair Kit SMAC112
SMAC-200SK	Repair Kit SMAC200
36.0643	1 1/2" & 2" Hannay Kit
36.0630	1 1/2" Chicksan Kit
36.0730	2" Chicksan Kit
38.0042	54 Ball Bearings, 1 1/2" Chicksan
38.0044	48 Ball Bearings, 2" Chicksan

Hannay Parts



Swivel Joint

Part No.	Description
SMAC112	1 1/2, 90° Swivel Joint
SMAC112ST	1 1/2, Straight Swivel
SMAC200	2", 90° Swivel Joint
SMAC200ST	2", Straight Swivel

SMAC 112

Sprockets, Motors, Chain and Links

	Part No.	Chain Type	Description	
Motors	15.0003	#35	12V DC 1/2 HP 650 RPM Motor 5/8" Shaft	Flange Mount
	15.0013			Base Mount Motor
	15.0003A			Flange Mount w/ 1 5/16" sprocket
	15.0009	#40 Heavy Duty	12V DC 2/3 HP 500 RPM Motor 5/8" Shaft	Flange Mount
Chain & Links	12.0001	#35	10 ft. Chain with Connecting link	
	12.0010		Connecting Link	
	12.0063	#40 Heavy Duty	4.5 ft. Chain with Connecting Link	
	12.0009		Connecting Link	
	12.0016		Half Link	
Sprockets	10.117	#35	Motor Sprocket 11 Tooth 5/8" Shaft 1 5/16" Long	
	10.119		Motor Sprocket 11 Tooth 5/8" Shaft 1 3/4" Long	
	10.116		Motor Sprocket 11 Tooth 5/8" Shaft 3/4" Long	
	10.1423		Drum Sprocket 138 Tooth	
	10.0417	#40 Heavy Duty	Motor Sprocket 9 Tooth 1 5/16" Long	
	10.3121		Drum Sprocket 104 Tooth	

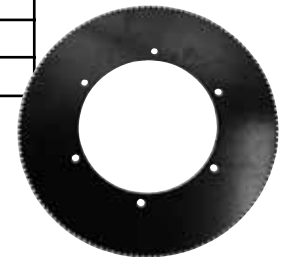

10.1423



15.0003A



38.0051
14 OZ. TUBE
OF GREASE

Note - Upgrade kit to heavy duty chain #40 (part number 20.3001) includes disc, motor sprockets, chain, carriage bolts & nuts as needed. Must specify model and serial number of reel being upgraded. Does not include motor.

39.0060



39.0041



Roller Assemblies

Part No.	Description
39.0041	FH338 Roller and Spool
39.0060	Assembly A Straight Roller

Note: Both rollers are stocked at the maximum length - cut to fit your reel. Parts available

2.1400



Bearings

Part No.	Description
2.1400	Back bearing w/ Bracket
2.1500	Back Bearing Only
2.1610	Front Bearing w/Bracket
2.1700	Front Bearing only
54.0022	1-1/2" Hub Space Washer



2.1610



54.0022

109

Hannay Reels and Reel Parts

NOTE: This drawing is for the parts chart on page 115. >>>>

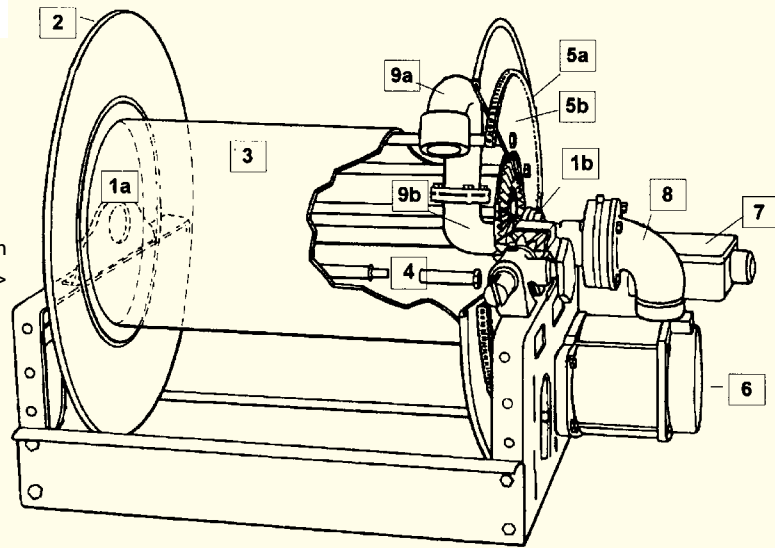

Note: Older model GM-600 may have different parts. Contact inside sales.

Note: Top wind bracket 44.0017
Bottom wind bracket 44.0016



Part Number	Drawing No.	Description	Quantity
45.1001	1	Roller Body Casting w/Mounting Bolts (for GM-700)	1
45.1002	2	Guide Arm Casting (for GM-700)	1
45.0009	3	Mounting Yoke with Bronze Bushings	1
17.0207	4	Switch Mounting Bracket (for GM-700)	1
17.0200	5	EPS-1 Explosion-Proof Switch	1
45.1003	6	Guidemaster Pinlock Assembly, S/S (for GM-700)	1
45.0024	7	SST Pivot Pin (with 1/4" cap screw & lock washer)	1
45.0019	8	GM-609 Roller (with 2 Pressed-in Ball Bearings)	2
45.0026	9	Gm-608 Ball Bearing	4
45.1004	10	Guidemaster Bottom Roller Plate (for GM-700)	1
54.0030	11	1/2" Lock Washer	2
54.0036	12	1/2"-13 Hex Nut	2
45.0015	13	1/4"-20 x 3/4" Socket Head Cap Screw	4
45.0013	14	5/16"-24 x 2 1/2" Plated Bolt with Nut	2
45.0027	15	5/16"- Hex Nut	2
45.0011	16	Oil-impregnated Bronze Bushing for Yoke	2
45.0015	17	1/4"-20 x 3/4" SST Socket Head Cap Screw	4
54.0008	18	1/2" Flat Washer	2
45.1005	19	Roller Mounting Bolt (threaded) for GM-700	2
45.0055	20	1/4"-20 x 5/8" SST Socket Head Cap Screw and Lock Washer	2

#1 Bearings	
1a Back Bearing	2.1400 Bearing complete w/bracket
	2.1500 Bearing only
1b Front Bearing	2.1600 Bearing complete w/bracket
	2.1700 Bearing only
#2 Disc	
2	Call for assistance. Need model # of reel or diameter of disc.
#3 Drum	
3	Call for assistance. Need model # of reel or length of drum.
#4 Carriage Bolts w/nuts	
4 Sized 1 1/2" OAL longer than drum length.	4.0226 15" long
	4.0229 17" long
	4.0232 19" long
	4.0235 21 1/2" long
	4.0238 23 1/2" long
#5 Chain/Sprocket	
5a Chain	12.0001 #35 Chain w/link
	12.0009 #40 Chain connect link
	12.0010 #35 Chain connect link
	12.0016 #40 Half Link
	12.0063 #40 Chain 4.5 ft use with 104T sprocket on pressed frame
5b Sprocket/Drive	10.1423 138 tooth sprocket
	10.3121 104 tooth sprocket, 16.65" diameter
5 Sprocket/Motor (Not Shown)	10.1011 9 tooth x 1" long...1/2" shaft
	10.1116 11 tooth x 3/4" long...5/8" shaft
	10.1117 11 tooth x 1 1/6" long...5/8" shaft
	10.1118 11 tooth x 1 5/16" long...5/8" shaft
	10.1119 11 tooth x 1 3/4" long...5/8" shaft
	10.0917 9 tooth, #40 chain sprocket, 1 5/16" long
#6 Motor	
6 Motor	15.0003A Flange mount, 1/2 HP w/sprocket
	15.0009 SX-043 12V DC Flange mount, 2/3 HP 500 RPM, SS shaft
	15.0013 Base mount, 1/2 HP, without sprocket
	16.0070 Set of 2 brushes
#7 Junction Box	
7 Junction Box	17.0030 Junction box - complete - square
	17.0060 Junction box - complete - new style
#8 Swivel Joint	
8 Swivel Joint	SMAC112ST 1 1/2" Straight (Smith)
	SMAC112 1 1/2" 90 Ell (Smith)
	31.4521 2" 90 Ell (Hannay)
	112 Roto Seal
	SMAC112 1 1/2" 90 Ell (Smith)
	SMAC112ST 1 1/2" Straight (Smith)
	SMAC200 2" 90 Ell (Smith)
	SMAC200ST 2" Straight (Smith)
8 Swivel Joint Repair Kit	36.0630 1 1/2" Chicksan
	36.0643 1 1/2" & 2" Buna N Pac/ for LP only
	36.0730 2" Chicksan
#9 Hub Assembly	
9a Hub Riser	1.2460 1" FNPT
	65.0021 Riser gasket
9b Hub (see insert at left)	1.3640A 13 1/2" B dimension
	1.3640B 15 1/2" B dimension
	1.3640C 17 1/2" B dimension
	1.3640D 20" B dimension
	1.3640E 22" B dimension